





## DOCUMENT CHANGE RECORD

Version Number	Date	Description
0.1	May, 01, 2007	Draft
0.2	May, 22, 2007	Updated the document to include details of the processing.
0.9	Jun 22, 2007	Updated the document based on the working sessions with CDX.
0.91	Jul 20, 2007	Incorporated EPA comments.
0.92	Aug 20, 2007	Incorporated comments from state users
1.0	Aug 29, 2007	Final Delivery
1.0 Revised	January 31, 2008	Updated Section 3.1, Step 7b and Section 3.2, Step 7b to correct the wording of the PDF report to CDX

## TABLE OF CONTENTS

<b>1. INTRODUCTION.....</b>	<b>4</b>
1.1 PURPOSE .....	4
1.2 ASSUMPTIONS AND CONSTRAINTS .....	4
1.3 AUDIENCE.....	5
1.4 DOCUMENT OVERVIEW .....	5
<b>2. XML DOCUMENT STRUCTURE.....</b>	<b>6</b>
2.1 OVERVIEW .....	6
2.2 HEADER DOCUMENT STRUCTURE .....	6
2.3 XML DOCUMENT STRUCTURE.....	7
<b>3. ICIS–NPDES BATCH FLOW DESCRIPTION.....</b>	<b>9</b>
3.1 FILE EXCHANGE IN NODE TO NODE CONFIGURATION.....	9
3.2 FILE EXCHANGE IN WEB FORM TO NODE CONFIGURATION .....	12
<b>4. ICIS–NPDES BATCH NODE WEB METHODS.....</b>	<b>16</b>
4.1 SUBMIT WEB METHOD .....	16
<b>5. CDX NODE WEB METHODS.....</b>	<b>17</b>
5.1 AUTHENTICATE WEB METHOD .....	17
5.2 SUBMIT WEB METHOD .....	17
5.3 NOTIFY WEB METHOD.....	18
<b>6. WEB METHODS USED BY STATE NODE.....</b>	<b>19</b>
6.1 AUTHENTICATE WEB METHOD .....	19
6.2 SUBMIT WEB METHOD .....	19
6.3 GET STATUS WEB METHOD.....	20
6.4 DOWNLOAD WEB METHOD.....	20
<b>APPENDIX A: ICIS–NPDES BATCH SUBMISSION TYPES .....</b>	<b>22</b>

**LIST OF FIGURES**

Figure 2-1 - XML Document Structure .....8  
Figure 3-1 - File Exchange in Node to Node Configuration .....10  
Figure 3-2 - File Exchange in Client to Node Configuration .....13

**LIST OF TABLES**

Table 2-1 - XML Document Details .....6

## 1. INTRODUCTION

---

The Integrated Compliance Information System – National Pollutant Discharge Elimination System (ICIS–NPDES) is being extended to support an integrated data flow to process electronic batch submissions using eXtensible Markup Language (XML) technology. Authorized states, tribes, and regional users submit National Pollutant Discharge Elimination System (NPDES) data via batch to ICIS–NPDES. They compose their transactions into predefined XML formatted files contained in a zip archive file and submit them to ICIS–NPDES through the Environmental Protection Agency’s (EPA) Central Data Exchange (CDX).

Upon receipt, CDX performs important functions on batch files such as validating the submitted data against approved XML schemas, scanning for viruses, archiving all XML files, and authenticating the submitters prior to making the XML files available for processing. CDX provides a Web services interface for distributing files to ICIS–NPDES for processing.

A Web service is deployed in the ICIS–NPDES environment to receive XML files from CDX. ICIS–NPDES is responsible for receiving and parsing the XML files, sequencing the transactions, and processing the transactions against the ICIS–NPDES service tier. For any transactions that are not successfully processed, detailed business-rule based errors will be generated. Finally, ICIS–NPDES records the batch processing results and sends the processing status back to CDX.

### 1.1 PURPOSE

The Flow Configuration Document (FCD) defines the required details to implement and configure a flow across the CDX and ICIS–NPDES nodes to exchange XML data. These nodes will implement a subset of the web methods from the Network Node Functional Specification to facilitate the exchange of data between the state users and the ICIS–NPDES Batch system. This document should be referenced in the context of submitting Discharge Monitoring Report (DMR) data to ICIS Batch. Future versions of this document will address ICIS full batch processing and batch submissions using NetDMR.

### 1.2 ASSUMPTIONS AND CONSTRAINTS

The following assumptions apply to the ICIS–NPDES Batch flow configuration:

- All batch files will be zipped by the submitting party prior to submittal to CDX.
- Upon receiving files from states, CDX validates the received files against the target XML schema. Only valid batches are submitted to ICIS–NPDES. A batch is valid if at least one of the files in that batch is valid XML file. A file is valid if it is well formed and complies with the ICIS NPDES schema.
- CDX scans the received files for any viruses. Files with viruses will be rejected.
- CDX archives the received files from state users.
- CDX supports both manual and automatic batch submissions. For manual submissions, users can log in to the ICIS–NPDES CDX Web Form to submit batches. For automatic submissions, users will choose to configure a node in their environment to submit

(“push”) the files to CDX, or have CDX retrieve (“pull”) the files (i.e., Node – Node). This document is prepared to explain the *Submit* (“push”) method to submit XML files to CDX.

### 1.3 AUDIENCE

The primary audience for this document is developers, project managers and architects throughout the ICIS–NPDES Batch implementation stakeholder organizations.

### 1.4 DOCUMENT OVERVIEW

The following sections comprise the rest of the document:

- **Section 2: XML Document Structure** – This section describes the overall structure of the ICIS–NPDES Batch XML Schemas.
- **Section 3: ICIS–NPDES Batch Flow Description** – This section describes the overall flow details for exchanging data between states, CDX and ICIS–NPDES.
- **Section 4: ICIS–NPDES Batch Node Web Methods** – This section describes the Web methods implemented by the ICIS–NPDES Batch node.
- **Section 5: CDX Node Web Methods** – This section describes the Web methods implemented by the CDX node.
- **Section 6: Web Methods Used by State Node** – This section describes the Web methods a state node can use to retrieve the required information CDX node.

## 2. XML DOCUMENT STRUCTURE

### 2.1 OVERVIEW

The ICIS–NPDES Batch Exchange Network Document is a XML file that contains metadata that facilitates the data processing and sandwiching of ICIS–NPDES data for a specific submission type. The Document is divided into two main sections, namely the header section and the payload section. The header section contains information about who submitted the Document, such as the author, their employer, creation time, and other information which will be described in the following sections. The payload section contains ICIS–NPDES data to update the ICIS–NPDES system. This data includes the payload submission type, transaction time, transaction type, and NPDES data corresponding to the selected submission type. The payload section may contain multiple payloads. Appendix A – ICIS–NPDES Batch Submission Type, contains all the submission types supported by ICIS–NPDES Batch.

### 2.2 HEADER DOCUMENT STRUCTURE

Authorized states, tribes, or regions submitting XML Documents must comply with the ICIS–NPDES Batch Document schema. The XML Document consists of a Header and a Payload section.

The following table, Table 2-1- XML Document Details, describes the major elements and attributes in the XML Document and how they are utilized during the processing of submitted data.

**Table 2-1 - XML Document Details**

<b>Header Section</b>				
<b>Element</b>	<b>Description</b>	<b>Example Value</b>	<b>Required</b>	<b>Notes</b>
Id	The ICIS username of the user submitting the XML document	Jdoe	Yes	The username is used to authenticate and authorize the user in ICIS
Author	The first and last name of the person generating the XML document	John Doe	No	Reference
Organization	The name of the company generating the XML document	State X Department of Environmental Quality	No	Reference
Title	The type of submission	Discharge Monitoring Report Submission	No	Reference
Creation Time	The date and time the document was created	2007-06-15T01:30:00.0Z	No	Reference
Comment	Free text information of the message contents	2nd resubmission of rejected transactions from May submission	No	Reference

<b>Header Section</b>				
<b>Element</b>	<b>Description</b>	<b>Example Value</b>	<b>Required</b>	<b>Notes</b>
Data Service	Name of backend application	ICIS	No	ICIS
Contact Info	Name, mailing address, city, state, zip, telephone number, and email address of the person who may be contacted with questions concerning the submission	John Doe 100 Somewhere St McLean, VA 22102	No	Reference
Property	Name Value pairs used to describe specific properties of the document		No	Not used
name	Name of the property	e-mail	Yes, if e-mail notification is desired, otherwise No	Used to identify the type of property. These are custom properties to facilitate the efficient communication of status.
value	Value of the property	jdoe@epa.gov	Yes, if name element is present	Used to communicate the processing status to the submitter.
<b>Payload Section</b>				
<b>Element</b>	<b>Description</b>	<b>Example Value</b>	<b>Required</b>	<b>Notes</b>
Operation (attribute)	This attribute provides the payload submission type	Discharge Monitoring Report Submission	Yes	
Transaction Type	The type of transaction that should be performed on the submitted data.	X, C, or R	Yes	
Transaction Timestamp	The date and time the data was extracted.	2001-12-17T09:30:47.0Z	Yes	

## 2.3 XML DOCUMENT STRUCTURE

A XML Document consists of a Header and a Payload section as depicted in Figure 2-1 – XML Document Structure. State systems creating the XML document should populate the required sections of the Header section with pertinent information. A batch submission may consist of one or more XML Documents. It is required that batches be submitted in compressed (zip file) format. If a batch submission contains any non XML files, they will be ignored during processing.

**Figure 2-1 - XML Document Structure**

```

<?xml version="1.0" encoding="UTF-8"?>
<Document xmlns=http://www.exchangenetwork.net/schema/icis/2 xmlns:xsi="http://www.w3.org/2001/XMLSchema-instance">
  <Header>
    <Id>test</Id>
    <Author>Author0</Author>
    <Organization>Organization0</Organization>
    <Title>Title0</Title>
    <CreationTime>2006-05-04T18:13:51.0Z</CreationTime>
    <Comment>Comment0</Comment>
    <DataService>DataService0</DataService>
    <ContactInfo>ContactInfo0</ContactInfo>
    <Property>
      <name>e-mail</name>
      <value>jdoe@epa.gov</value>
    </Property>
  </Header>
  <Payload Operation="DischargeMonitoringReportSubmission">
    <DischargeMonitoringReportData>
      <TransactionHeader>
        <TransactionType>C</TransactionType>
        <TransactionTimestamp>2001-12-17T09:30:47.0Z</TransactionTimestamp>
      </TransactionHeader>
      <DischargeMonitoringReport>
        <PermitIdentifier>DCBATTEST</PermitIdentifier>
        <PermittedFeatureIdentifier>001</PermittedFeatureIdentifier>
        <LimitSetDesignator>A</LimitSetDesignator>
        <MonitoringPeriodEndDate>2007-02-28T05:00:00Z</MonitoringPeriodEndDate>
        <PrincipalExecutiveOfficerFirstName>XXX</PrincipalExecutiveOfficerFirstName>
        <ReportParameter>
          <ParameterCode>01000</ParameterCode>
          <MonitoringSiteDescriptionCode>1</MonitoringSiteDescriptionCode>
          <LimitSeasonNumber>0</LimitSeasonNumber>
          <NumericReport>
            <NumericReportCode>C1</NumericReportCode>
            <NumericReportReceivedDate>2007-01-31</NumericReportReceivedDate>
            <NumericConditionQuantity>0.5</NumericConditionQuantity>
          </NumericReport>
        </ReportParameter>
      </DischargeMonitoringReport>
    </DischargeMonitoringReportData>
  </Payload>
</Document>

```

### **3. ICIS–NPDES BATCH FLOW DESCRIPTION**

---

A node is a service provider on the exchange network conforming to the Network Node Functional Specification. The Network Node Functional Specification describes the behavior and interfaces of the service provider component. The specification is available on the Exchange Network website ([www.exchangenetwork.net](http://www.exchangenetwork.net)). CDX deploys a node to accept batch submissions from the state users. The ICIS–NPDES Batch system deploys a Web services node in the ICIS–NPDES environment to facilitate the receipt of NPDES data from the CDX node. The key interfaces that can be implemented in a Network Node include the following Web Methods:

- Authenticate
- Submit
- Query
- GetStatus
- Notify
- Solicit
- Download
- NodePing
- GetServices
- Execute (optional)

#### **3.1 FILE EXCHANGE IN NODE TO NODE CONFIGURATION**

The ICIS–NPDES node implements the Submit method to receive the batch submissions from CDX. Figure 2.1 – File Exchange in Node to Node Configuration, describes the steps involved in exchanging the files between the states, CDX and ICIS–NPDES Batch for this configuration. In this deployment, an exchange node is configured in the state, CDX and ICIS–NPDES Batch environments. The following steps describe the details of the batch submissions in this configuration:

**Figure 3-1 - File Exchange in Node to Node Configuration**

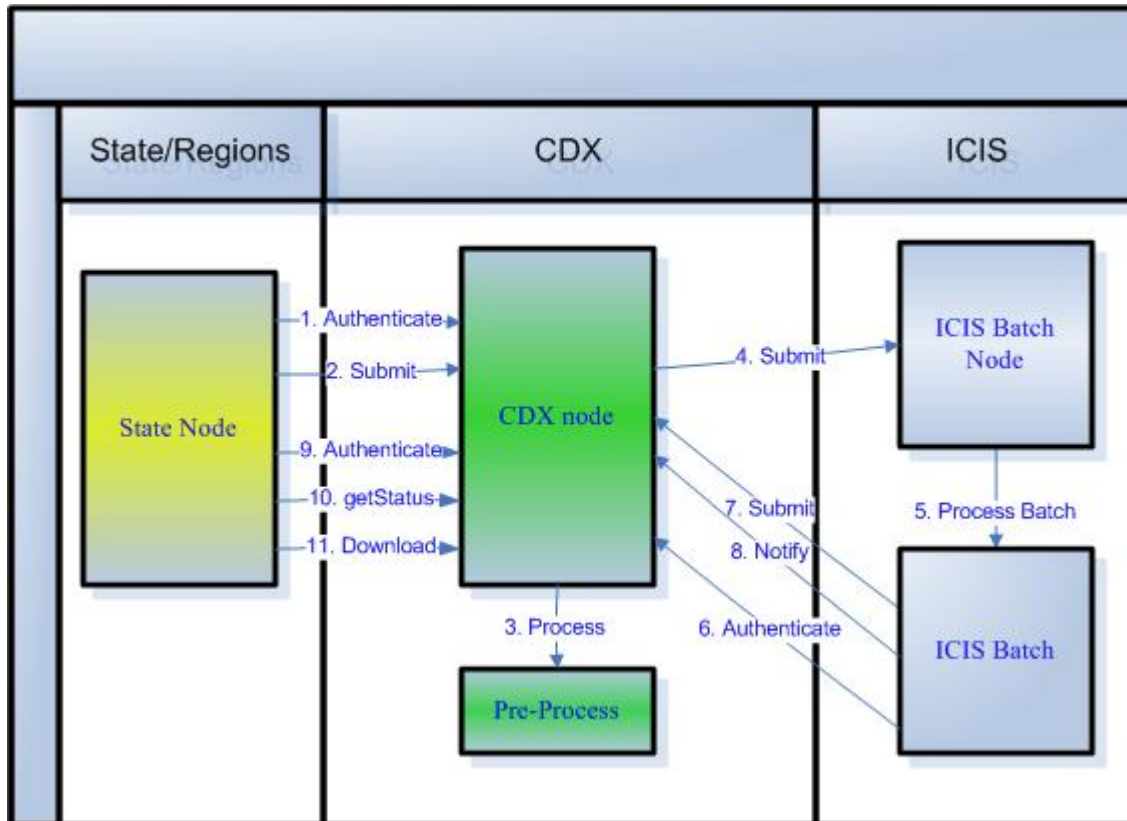

1. Before submitting a document to CDX, the state node uses the *Authenticate* method by supplying a CDX user id and password to authenticate. Upon successful authentication CDX returns a securityToken to the state node. If the supplied user id, password combination is invalid, a SOAP fault with a detail element with “E\_UnknownUser” as the error code is returned to the invoker.
2. The state node uses the *Submit* method to submit the batch data and the issued security Token (from Step 1) to CDX.
  - a. CDX validates the security token. If the security token is invalid, the entire batch is rejected and a SOAP fault is returned to the client and the processing of the batch ends. If the security token is valid, processing continues at step b.
  - b. CDX archives the received batch files. Received batches will be archived for a total of five years. They will be maintained in an easily accessible archive for one month. Once stored for a month, the archived batches will be moved to a secondary storage device like a tape. These tapes will be maintained for a total elapsed time from time of receipt of batch for five years.
  - c. If all of the submitted files in the batch are XML files, the submitted batch is saved. The batch status is set to “Received” and a Transaction ID is generated and returned to the client. The processing continues at step 3.

3. Upon receiving the files from the state node, the CDX node unzips the compressed batch submissions and performs the following process:
  - a. Validates the submitted files are free from virus. If all of the files contain a virus, the entire batch submission is rejected and the batch status is set to “Failed”. If any files are free from virus, the status remains set to “Received” and the valid files continue processing at step b.
  - b. Valid files from step “a” are validated against the target XML schema. If all of the files are invalid, the entire batch submission is rejected and the batch status is set to “Failed”. If any files are valid, the batch status remains set to “Received” and the valid files continue processing at step c.
  - c. The QA server at CDX creates a report with the status of the validations. This report can be downloaded using the “*Download*” web method on the CDX node.
  - d. If steps “a” through “c” complete successfully, valid files from the batch are archived. Valid batches to be passed to ICIS–NPDES will be archived in an easily accessible storage area for one month. At the end of the month, the archived batches will be permanently deleted.
  - e. If steps a through d complete successfully, the batch status is set to “Pending” and the process continues at step 4.
4. CDX submits the valid files from the batch to the ICIS–NPDES Batch node by invoking the *Submit* method on the ICIS–NPDES Batch node.
  - a. The ICIS–NPDES Batch node stores the received files and the corresponding Transaction ID supplied by CDX for parsing. The received files are stored until the batch process for the corresponding files is complete.
  - b. The ICIS–NPDES Batch node acknowledges the receipt of the batch files.
5. ICIS–NPDES Batch validates the ICIS–NPDES user id submitted with the batch submission.
  - a. If the user id is invalid, an error message is captured in the ICIS–NPDES batch logs. If all of the submitted files have invalid user ids, the process continues at step 6.
  - b. If the user id is valid for at least one of the files in the submission, ICIS–NPDES Batch parses and processes the valid files according to the predefined processing logic.
6. In preparing to submit the processing details to CDX, the ICIS–NPDES Batch node authenticates itself by invoking the *Authenticate* method on CDX. On successful authentication, CDX returns a security Token.
7. ICIS–NPDES Batch creates a PDF document with the processing status.
  - a. If critical errors (e.g., an invalid ICIS user id populated in the XML files) prevented the processing of a received batch, a PDF document noting these critical errors along with the Transaction ID for the Batch will be generated. Processing continues at step c.

- b. If no critical errors occur and the batch is processed, a PDF document with status message “Batch [CDX Transaction ID] has processed in ICIS. Please log on to ICIS to retrieve the audit reports.” is created. Processing continues at step c.
  - c. The ICIS–NPDES Batch node uses the *Submit* method to send the PDF document created in step “b” to the CDX node. The CDX node archives the received PDF document..
8. After submitting the processing report to CDX, ICIS–NPDES Batch uses the *Notify* method to update the processing status of the batch at CDX. The CDX node updates the batch status to “Completed”.
9. In preparation for retrieving the batch processing status and the processing documents the state node obtains a securityToken by supplying the user id and password credentials to the *Authenticate* method on the CDX node. As described in step 1, the *Authenticate* method returns a SOAP fault in case of failed authentication.
10. Using the Transaction ID provided by CDX in step 2, the state node retrieves the batch status at regular intervals using *getStatus* method.
11. When the batch status is “Completed”, the state node downloads the batch processing documents for that specific Transaction ID from the CDX node using the *Download* method.

### 3.2 FILE EXCHANGE IN WEB FORM TO NODE CONFIGURATION

In this configuration, state users submit batches using the ICIS–NPDES CDX Web Form. Before submitting a batch, the user logs into CDX using a pre-established user id and password. Upon successful authentication, the user can submit the files to CDX. All batch files should be compressed prior to submitting to CDX. CDX returns a Transaction ID after receiving the batch submission. Figure 3-2 – File Exchange in Client to Node Configuration, describes the steps involved in exchanging the files between the states, CDX and ICIS–NPDES Batch for this configuration.

**Figure 3-2 - File Exchange in Client to Node Configuration**

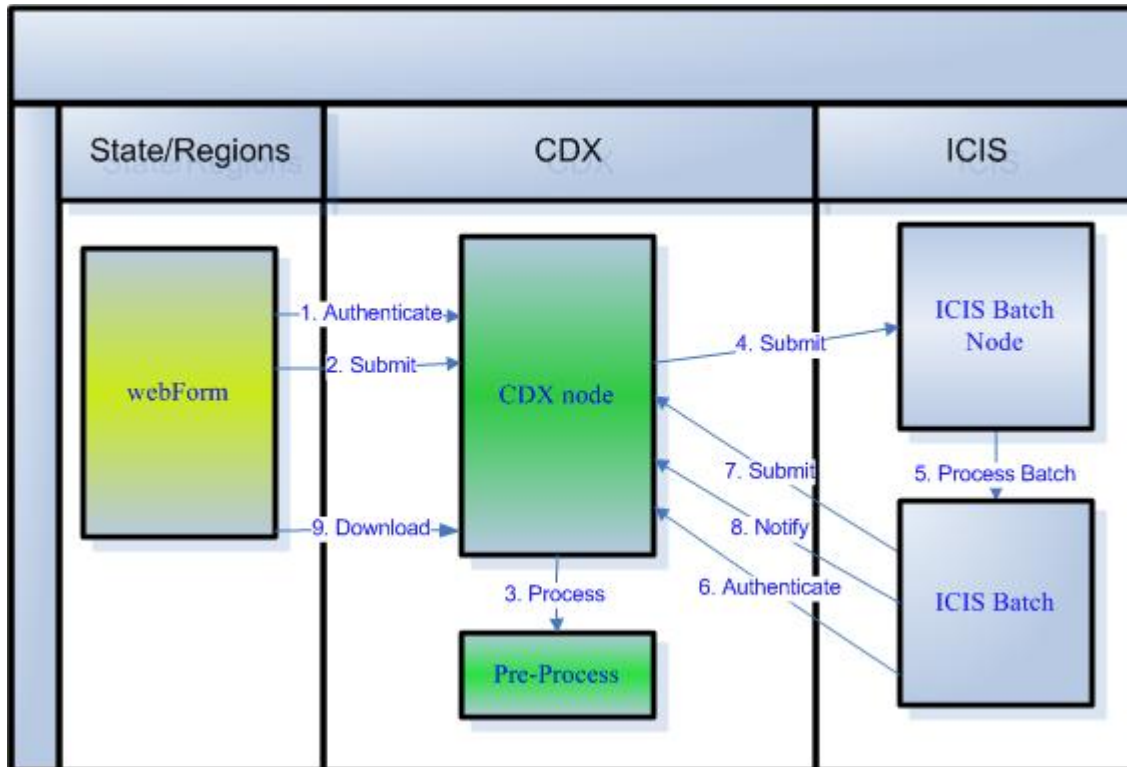

1. Before submitting a document to CDX, the state user logs into the CDX using the ICIS–NPDES CDX Web Form.
2. Upon successful login, the state user uploads a batch to CDX.
  - a. CDX validates the security token. If the security token is invalid, the entire batch is rejected, an error is displayed to the user and the processing of the batch ends. If the security token is valid, processing continues at step b.
  - b. CDX archives the received batch files. Received batches will be archived for a total of five years. They will be maintained in an easily accessible archive for one month. Once stored for a month, the archived batches will be moved to a secondary storage device like a tape. These tapes will be maintained for a total elapsed time from time of receipt of batch for five years.
  - c. If all of the submitted files in the batch are XML files, the submitted batch is saved, batch status is set to “Received” and a Transaction ID is generated and returned to the client. The Web Form is refreshed with the received Transaction ID. The processing continues at step 3.
3. Upon receiving the files from the ICIS–NPDES CDX Web Form the CDX node unzips compressed batch submissions and performs the following process:
  - a. Validates the submitted files are free from virus. If all of the files contain a virus, the entire batch submission is rejected and the batch status is set to “Failed”. If

- any of the files are free from virus, the status remains set to “Received” and the process continues at step b.
- b. Valid files from step “a” are validated against the target XML schema. If all of the files are invalid, the entire batch submission is rejected and the batch status is set to “Failed”. If any files are valid, the batch status remains set to “Received” and the valid files continue processing at step c.
  - c. The QA server at CDX creates a report with the status of the validations. This report can be downloaded to view the validation errors of the submitted files.
  - d. If steps “a” through “c” complete successfully, valid files from the batch are archived. Valid batches to be passed to ICIS–NPDES will be archived in an easily accessible storage area for one month. At the end of the month, the archived batches will be permanently deleted.
  - e. If steps a through d complete successfully, the batch status is set to “Pending” and the process continues at step 4.
4. CDX submits the valid files from the batch to the ICIS–NPDES node by invoking the *Submit* method on the ICIS–NPDES Batch node.
    - a. The ICIS–NPDES Batch node stores the received files and the corresponding Transaction ID supplied by CDX for parsing. The received files are stored until the batch process for the corresponding files is complete.
    - b. The ICIS–NPDES Batch node acknowledges the receipt of the batch files.
  5. ICIS–NPDES Batch validates the user id submitted with the batch submission.
    - a. If the user id is invalid, an error message is captured in the ICIS–NPDES batch logs. If all of the submitted files have invalid user ids, the process continues at step 6.
    - b. If the user id is valid for at least one file in the submission, ICIS–NPDES Batch parses and processes the valid files according to the predefined processing logic.
  6. In preparing to submit the processing details to CDX, the ICIS–NPDES Batch node authenticates itself by invoking the *Authenticate* method on CDX. On successful authentication, CDX returns a securityToken.
  7. ICIS–NPDES Batch creates a PDF document with the processing status.
    - a. If critical errors (e.g., an invalid ICIS user id populated in the XML files) prevented the processing of a received batch, a PDF document noting these critical errors along with the Transaction ID for the Batch will be generated. Processing continues at step c.
    - b. If no critical errors occur and the batch is processed, a PDF document with status message “Batch [CDX Transaction ID] has processed in ICIS. Please log on to ICIS to retrieve the audit reports.” is created. Processing continues at step c.
    - c. The ICIS–NPDES Batch node uses the *Submit* method to send this document to the CDX node. The CDX node archives the received PDF document.

8. After submitting the processing report to CDX, ICIS–NPDES Batch node uses the *Notify* method to update the processing status of the batch at CDX. The CDX node updates the batch status to “Complete”.
9. The state user logs in to the ICIS–NPDES CDX Web Form, which shows a status of “Complete”, and selects the transaction history to view all the processing details and documents related to the batch transaction including the ICIS–NPDES Batch Processing Status PDF.

## 4. ICIS–NPDES BATCH NODE WEB METHODS

---

ICIS–NPDES Batch implements the following Web services from the methods defined in the Network Node Functional Specification to accept batch submissions from CDX:

- Submit - CDX invokes this Web method to submit files to ICIS–NPDES Batch.

### 4.1 SUBMIT WEB METHOD

**Description:**

Submit is a utility method used to send one or more files to a service provider. A positive response from the node indicates that the files were successfully received. An exception message means that the submitted documents were not delivered to the recipient. The ICIS–NPDES Batch node returns the Transaction ID it received in the submission to indicate the files were received successfully.

**Arguments:**

The Submit method has four arguments

- securityToken: A security ticket issued by the service provider.
- transactionId: CDX sends a unique transactionId along with the submission.
- dataflow: The name of the target dataflow. In this case, “ICIS–NPDES”.
- documents: An array of documents of type nodeDocument. This argument contains the XML documents for the specific Transaction ID.

**Return:**

- When successful, the Submit method returns the transactionId it received from the CDX node. In case of an error, the ICIS–NPDES Batch node returns a SOAP Fault with the details of the errors that occurred while receiving the batch.

## 5. CDX NODE WEB METHODS

---

CDX implements the following Web methods from the methods defined in the Network Node Functional Specification to facilitate authentication and accept batch processing status from the ICIS–NPDES Batch node:

- **Authenticate** - ICIS–NPDES Batch obtains a securityToken before initiating Submit and Notify.
- **Submit** - ICIS–NPDES Batch Submits an ICIS–NPDES Batch Processing Status PDF document with Batch/File level errors or a notice of successful processing to CDX.
- **Notify** - ICIS–NPDES Batch notifies CDX of the final Batch Processing Status.

### 5.1 AUTHENTICATE WEB METHOD

**Description:**

The Authenticate method authenticates a user using the supplied credentials. Upon successful authentication, it returns a securityToken. The securityToken is used while invoking the Notify and Submit methods on CDX.

**Arguments:**

The Authenticate method has three arguments:

- **userId**: The User id to be authenticated. The ICIS–NPDES Batch node sends the user id assigned to the ICIS–NPDES Batch node.
- **credential**: User password for accessing the CDX node.
- **authenticationMethod**: Specifies which authentication methods are to be used. In this case, it will be user id and password.

**Return:**

- Upon successful authentication, the service provider returns a securityToken wrapped in a SOAP message. If authentication fails, a SOAP fault message with error details is returned.

### 5.2 SUBMIT WEB METHOD

**Description:**

ICIS–NPDES Batch invokes the Submit method on CDX node to send the processing status document to CDX. In case of critical errors which cause a file or batch to be rejected (e.g., invalid user id), the ICIS–NPDES Batch Processing Status Document will report these errors. If no critical errors are received while processing a batch, the ICIS–NPDES Batch Processing Status Document will contain a message indicating the successful completion of processing for that batch.

**Arguments:**

The Submit method has five arguments:

- URL: URL for the CDX node.
- securityToken: A security token issued by the service provider (NAAS).
- transactionId: The transactionId associated with the processed batch. CDX assigns a unique transactionId for each batch submitted to ICIS–NPDES Batch.
- dataflow: The target dataflow name. In this case, “ICIS–NPDES”.
- documents: An array of documents of type nodeDocument. ICIS–NPDES Batch will submit the ICIS–NPDES Batch Processing Status Document.

**Return:**

- The Submit method returns the transactionId submitted while invoking the Submit method. If the submission fails, a SOAP fault with details of the error will be returned.

### 5.3 NOTIFY WEB METHOD

**Description:**

The Notify method can be used for three purposes: document notification, event notification, and status notification. ICIS–NPDES Batch uses the notify method to inform CDX about the status of a processed batch for a given Transaction ID.

**Arguments:**

The Notify method has four arguments:

- securityToken: A security ticket issued by the service provider (NAAS).
- nodeAddress: For document notification, the parameter contains a network node address where the document can be downloaded. For event and status notifications, it should contain the initiator’s Node address. ICIS–NPDES Batch sets the argument to “https://dev.epacdxnode.net/cdx/services/DataflowService”
- dataflow: This parameter contains a URL to indicate the type of notification. There are three kinds of notifications, an event, a status or a document. ICIS–NPDES Batch node uses “http://www.exchangenetwork.net/node/status” to indicate status notification.
- documents: An array of documents of type nodeDocument. ICIS–NPDES Batch will provide a nodeDocument with the transaction ID and batch processing status of “Processed”.

**Return:**

- For status notification, the CDX node returns a string other than transactionId signaling the acceptance of the status.

## 6. WEB METHODS USED BY STATE NODE

---

State nodes will invoke the following Web methods on CDX to submit batches to CDX, get status of a batch submission and download any processing status documents including error reports from CDX:

- Authenticate – State node obtains a securityToken before initiating Submit, GetStatus, or Download.
- Submit – State node invokes this method on CDX node to submit a batch.
- GetStatus – State node invokes this method on CDX node to obtain the batch status.
- Download – State node invokes this method on CDX node to download the processing status documents related to a batch submission.

### 6.1 AUTHENTICATE WEB METHOD

#### Description:

The State node invokes the Authenticate method on CDX node to authenticate a user using the supplied credentials like user id and password. Upon successful authentication, CDX returns a securityToken. The securityToken is used while invoking the Submit, GetStatus and Download methods on CDX.

#### Arguments:

The Authenticate method has three arguments:

- **userId:** The User id to be authenticated. The state node sends the CDX userid assigned to the state node.
- **credential:** User password for accessing the CDX node.
- **authenticationMethod:** Specifies which authentication methods are to be used. In this case, it will be user id and password.

#### Return:

- Upon successful authentication, the service provider returns a securityToken wrapped in a SOAP message. If authentication fails, a SOAP fault message with error details is returned.

### 6.2 SUBMIT WEB METHOD

#### Description:

The state node invokes the Submit method on CDX node to submit a batch.

#### Arguments:

The Submit method has five arguments:

- **URL:** URL for the CDX node.
- **securityToken:** A security token issued by the service provider (NAAS).

- transactionId: The transactionId associated with the batch. While submitting batches this is always empty.
- dataflow: The target dataflow name. In this case, “ICIS–NPDES”.
- documents: An array of documents of type nodeDocument. ICIS–NPDES The state node will submit XML document(s).

**Return:**

- The Submit method returns the transactionId associated with the batch submission. If the submission fails, a SOAP fault with details of the error will be returned.

### 6.3 GET STATUS WEB METHOD

**Description:**

The GetStatus web method is used for retrieving the current status of the batch. As described in section 3.1 a batch could be in Receiving, Pending or Completed status.

**Arguments:**

The GetStatus method has two arguments:

- securityToken: A security ticket issued by the service provider (NAAS). It is required.
- transactionId: The transactionId associated with the batch. When a batch is submitted to CDX, a transactionId is returned for successful submissions.

**Return:**

- This method returns a description of the current status of the batch if the operation is successful. A list of batch statuses is described in section 3.1. This method returns a SOAP Fault with an error code of E\_TransactionId if the transaction ID is invalid; it returns a SOAP Fault with an error code of E\_InvalidToken or E\_TokenExpired if the securityToken is invalid or expired.

### 6.4 DOWNLOAD WEB METHOD

**Description:**

The state node invokes the Download method on CDX node to download all the processing status documents associated with a batch submission. These documents include the QA report (contains XML validation errors if any), Batch processing status and processing error reports from ICIS–NPDES. Prior to invoking this method it is recommended to call the GetStatus method to verify the batch status.

**Arguments:**

The Download method has four arguments:

- securityToken: A security ticket issued by the service provider (NAAS).
- transactionId: The transactionId associated with the batch. When a batch is submitted to CDX, a transactionId is returned for successful submissions.
- dataflow: Empty string.

- documents: An array of documents of type nodeDocument. This should be set to empty.

**Return:**

- The response contains a dataflow identifier and a set of documents. Documents transmitted can be either embedded payloads or separate attachments. If the Download fails, a SOAP fault with details of the error will be returned.

## APPENDIX A: ICIS–NPDES BATCH SUBMISSION TYPES

ICIS–NPDES Batch supports the following submission types:

- FacilityPermit Basic (Individual Permits)
- Master General Permit
- General Permit Covered Facility
- Unpermitted Facility
- Biosolids Permit Component
- CAFO Permit Component
- CSO Permit Component
- Pretreatment Permit Component
- POTW Permit Component
- SW Construction Permit Component
- SW Industrial Permit Component
- SW MS4 Medium/Large Permit Component
- SW MS4 Small Permit Component
- Permitted Feature
- Limit Set
- Limit (Permit)
- Change Keys(Limits)
- Effluent Trade Partner
- Narrative Condition
- Permit Schedule
- Permit Tracking Event
- Biosolids Program Report
- CAFO Annual Report
- CSO Event Report
- Local Limits Report
- Pretreatment Performance Summary
- SSO Annual Report
- SSO Event Report
- SSO Monthly Event Report
- SW Event Report
- SW MS4 Program Report
- Compliance Monitoring
- CAFO Inspection
- CSO Inspection
- Pretreatment Inspection
- SSO Inspection
- SW Inspection
- Compliance Monitoring Linkage
- Formal Enforcement Action
- Informal Enforcement Action
- Sub Activity
- Compliance Schedule

- Limit (Enforcement Action)
- Change Keys (EA Limits)
- Discharge Monitoring Report
- DMR Program Report Linkage
- DMR Violation
- Single Event Violation
- Enforcement Action Violation Key.